

1.1.2.10 Short Exposure High Power Sensors - Pulsed Power Mode

300mW to 10,000W

Features

- No water cooling
- Measure up to 10kW
- Cost Effective
- Diffuser for concentrated beams

L40(250)A-LP2-50



L40(500)A-LP2-DIF-35



L30C-LP2-26-SH



If the full features of the Helios Pro or Ariel including protective cover, Profinet interface and pulse width measurement are not needed, similar performance can be obtained with the L40(250)A-LP2-50 and L40(500)A-LP2-DIF-35. The L40(250)A-LP2-50 has the same sensor as the Helios Pro. It can measure powers from short exposure from 500W up to 10,000W. The user measures the energy of the pulse and knowing the pulse width calculates the power (e.g. 5000J in a 0.5s pulse = 10,000W). If using the Centauri and

StarBright meters or Juno/Juno+/Juno-RS PC interfaces this can be calculated directly by inputting the laser pulse width into the Pulsed Power screen of the Meter/Interface or the equivalent StarLab screen and exposing the sensor to the power for the requisite pulse width. The meter will then directly give the power reading from the pulse energy measured. For lower powers, the L30C-LP2-26-SH will give similar performance for energies up to 2000J. For further information see pages 68 & 160.

| Model | L40(250)A-LP2-50 | L40(500)A-LP2-DIF-35 | L30C-LP2-26-SH | | | | | | |
|---|---|--|---|---------------|------------------------|-----------------------------------|---------------|------------------------|-----------------------------------|
| Absorber Type | LP2 | LP2 + Diffuser | LP2 | | | | | | |
| Spectral Range | 0.25 – 2.2µm, 2.94µm | 0.44 – 2.2µm ^(e) | 0.25 – 2.2µm | | | | | | |
| Aperture | Ø50mm | Ø35mm | Ø26mm | | | | | | |
| Absorption | >94% from 0.25 to 1.1µm | ~14% backscatter from diffuser | >94% from 0.25 to 1.1µm | | | | | | |
| Power Range for continuous use | 300mW - 40W | 300mW - 40W | 300mW - 10W | | | | | | |
| Maximum Intermittent CW power | 250W for 1.5min, 150W for 3min, 80W for 6min, 40W continuous | 500W for 45s, 250W for 1.5min, 150W for 3min, 80W for 6min, 40W continuous | 10W continuous, 100W for 2min, 100W heat sunk | | | | | | |
| Maximum CW power density | 20kW/cm ² at 250W | >150kW/cm ² at 500W | 42kW/cm ² at 100W | | | | | | |
| Aperture | Ø50mm | Ø35mm | Ø26mm | | | | | | |
| Max Beam Diameter for Gaussian beam | Ø35mm for up to 30deg incidence | Ø25mm for normal incidence Ø15mm for 20deg incidence ^(f) Ø10mm for 30deg incidence ^(f) | Ø17mm for up to 30deg incidence | | | | | | |
| Pulsed Power Mode | | | | | | | | | |
| Exposure Time For Pulsed Power Mode (see table below) | 0.3s - 2s ^(b) | 0.3s - 4s ^(b) | 0.5s - 4s ^(b) | | | | | | |
| Energy Range | 100mJ – 10,000J | 100mJ – 2000J | 30mJ – 2000J | | | | | | |
| Energy Accuracy | ±5% 700 – 1100nm ^{(a), (c)} | ±5% 900 – 1100nm ^(c) | ±5% 700 – 1100nm ^{(a), (c)} | | | | | | |
| Linearity with Energy | ±1.5% ^(d) | ±1.5% ^(d) | ±1.5% ^(d) | | | | | | |
| Reproducibility | ±1% | ±1% | ±1% | | | | | | |
| Response Time | 2.5s | 2.5s | 1.5s | | | | | | |
| Waiting Time for Next Measurement | 12s | 12s | 12s | | | | | | |
| Maximum Exposure Before Cooling Down is Necessary | 20kJ (e.g. 4 shots of 5000Wx1s). Cooling down time before another 20kJ series, 10min. | 8kJ (e.g. 4 shots of 2000Wx1s). Cooling down time before another 8kJ series, 10min. | 10kJ (e.g. 5 shots of 2000Wx1s). Cooling down time before another 10kJ series, 10min. | | | | | | |
| Recommended Exposure Times and Beam Diameters | Laser Power W | Recommended Exposure s | Min 1/e ² beam dia. mm | Laser Power W | Recommended Exposure s | Min 1/e ² beam dia. mm | Laser Power W | Recommended Exposure s | Min 1/e ² beam dia. mm |
| | 500 | 2 | 9 | 100 | 4 | 1 | 100 | 4 | 9 |
| | 1000 | 1 | 9 | 500 | 1 | 1 | 500 | 1 | 9 |
| | 2000 | 1 | 12 | 1000 | 1 | 1 | 1000 | 1 | 13 |
| | 4000 | 1 | 16 | 2000 | 1 | 1.5 | 2000 | 1 | 17 |
| | 5000 | 1 | 18 | 4000 | 0.4 | 3.5 | 4000 | 0.5 | 22 |
| 10000 | 0.3 | 22 | | | | | | | |
| Compatible Meter/PC interface | Centauri, StarBright, Juno/Juno+/Juno-RS with StarLab | Centauri, StarBright, Juno/Juno+/Juno-RS with StarLab | Centauri, StarBright, Juno/Juno+/Juno-RS with StarLab | | | | | | |
| Weight kg | 0.6 | 0.6 | 0.3 | | | | | | |
| Operating Temperature | 15-60°C | 15-60°C | 15-60°C | | | | | | |
| Connections | DB15 Smart Plug | DB15 Smart Plug | DB15 Smart Plug | | | | | | |
| Compliance | CE, UKCA, China RoHS | CE, UKCA, China RoHS | CE, UKCA, China RoHS | | | | | | |
| Part Number | 7Z02794 (see page 68) | 7Z02797 (see page 68) | 7Z02775 (see page 160) | | | | | | |

Notes: (a) Above 1100nm there is an additional 1% uncertainty

(b) Repetitive pulses can also be measured as long as the total exposure time is within this range

(c) The power is calculated by measuring the energy and exposure time. The laser pulse is assumed to be rectangular for this calculation

(d) For pulse widths in the range 0.3 – 4s

(e) Calibrated for 900 – 1100nm

(f) At large angles of incidence, the position the beam hits the absorber should be offset into the direction of incidence by 5-10mm for correct reading and at 20deg incidence the reading will be 5% lower and at 30deg incidence 10% lower

* For drawings please see page 111

Pulsed Power Mode Screen:

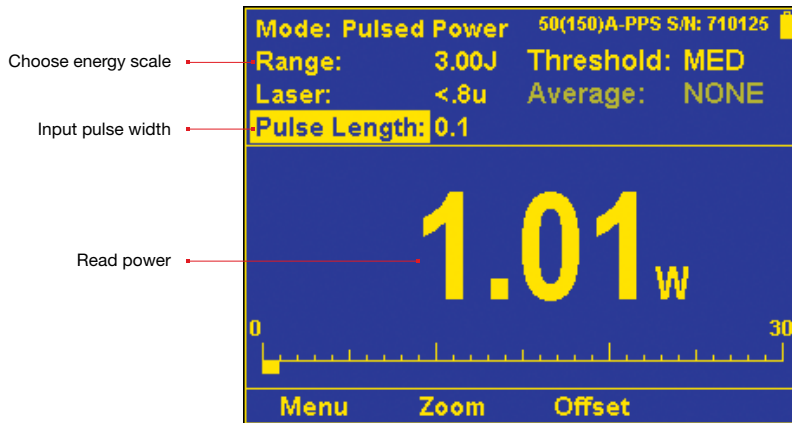

L40(250)A-LP2-50

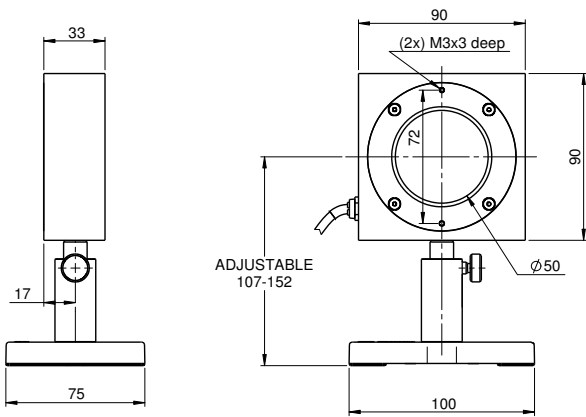

L30C-LP2-26-SH

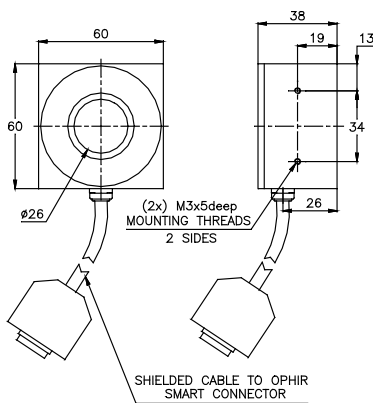

L40(500)A-LP2-DIF-35

