

## 1.1.2.5 Medium Power Large Aperture Thermal Sensors - Apertures 65mm

### 1.1.2.5.1 Sensors for Intense Pulsed Light IPL

100mJ to 2000J

#### Features

- L50(300)A-IPL: Large aperture with glass for gel coupling
- L40(150)A-IPL: Designed for gel coupled sources
- L50(300)A-LP2-65: Large aperture and low angle dependence

L50(300)A-IPL



L40(150)A-IPL



L50(300)A-LP2-65



Model	L50(300)A-IPL	L40(150)A-IPL	L50(300)A-LP2-65
Use	Gel and Air coupled IPL and laser sources	Gel coupled IPL sources and laser sources	Air coupled IPL and laser sources
Absorber Type	LP2 + coated window <sup>(a)</sup>	LP2 + pyramid coupling to capture large output light angles	LP2
Spectral Range $\mu\text{m}$	0.5 - 1.3	0.5 - 1.3	0.25 – 2.2
Absorption	86%	92%	>94% from 0.25 to 1.1 $\mu\text{m}$
Aperture mm	$\varnothing$ 65mm	22x22mm <sup>(b)</sup>	$\varnothing$ 65mm
<b>Power Mode</b>			
Power Range	400mW - 300W	NA	400mW - 300W
Maximum Intermittent Power	300W for 2 min, 150W for 4.5min, 50W continuous	NA	300W for 2min, 150W for 4.5min, 50W continuous
Power Scales	300W / 30W	NA	300W / 30W
Power Noise Level	20mW	NA	20mW
Maximum Average Power Density kW/cm <sup>2</sup>	17 at 300W 50 at 50W	NA	17 at 300W 50 at 50W
Response Time with Meter (0-95%) typ. s	3	NA	3
Calibration Uncertainty $\pm\%$	1.9	NA	1.9
Power Accuracy $\pm\%$	6 for most gel or air coupled IPL sources	NA	3 <sup>(e)</sup>
Linearity with Power $\pm\%$	1	NA	1
<b>Energy Mode</b>			
Energy Range	120mJ - 1000J	100mJ - 2000J	200mJ – 1000J
Energy Scales	1000J / 600J / 60J / 6J	2000J / 600J / 60J / 6J	1000J / 600J / 60J / 6J
Minimum Energy mJ	120	100	200
Damage Threshold	Maximum Energy Density J/cm <sup>2</sup>	Maximum Energy J	Maximum Energy Density J/cm <sup>2</sup>
<100ns	0.1	1	0.1
1 $\mu\text{s}$	0.9	9	0.9
0.5ms	50	500	50
2ms	130	1300	130
10ms	400	2000	400
Energy Accuracy $\pm\%$	8 for gel coupled source <sup>(c)</sup> 5 for air coupled source	8 for gel coupled source <sup>(c)</sup>	5 for air coupled source <sup>(d)</sup>
Cooling	convection / ballistic	convection / ballistic	convection / ballistic
Weight kg	1.0	1.0	0.9
Compliance	CE, UKCA, China RoHS	CE, UKCA, China RoHS	CE, UKCA, China RoHS
Version	V1		
Part number	<b>7Z02780</b>	<b>7Z02771</b>	<b>7Z02782</b>

Note: (a) Sensor has a window for gel coupled IPL sources where IPL source is coupled to window with gel or water for measurement. Can also measure air coupled IPLs.

Note: (b) If the source is longer than the aperture, it can overfill and the output can be calculated proportionately.

Note: (d) Accurate measurement of air coupled sources due to low angular dependence of LP2 coating. See graph on page 75.

Note: (e) Above 1.1 $\mu\text{m}$  there is an additional calibration uncertainty of up to 2%.

Note: (c) The assumed angular distribution of the IPL light is given below. The angle dependence of the LP2 coating is shown on page 75.

\* For drawings and graphs please see page 75

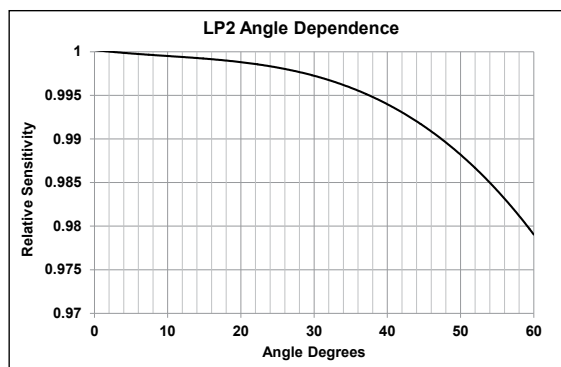
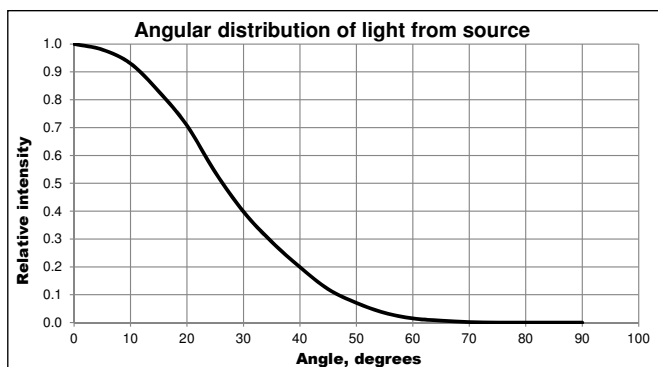

L50(300)A-IPL

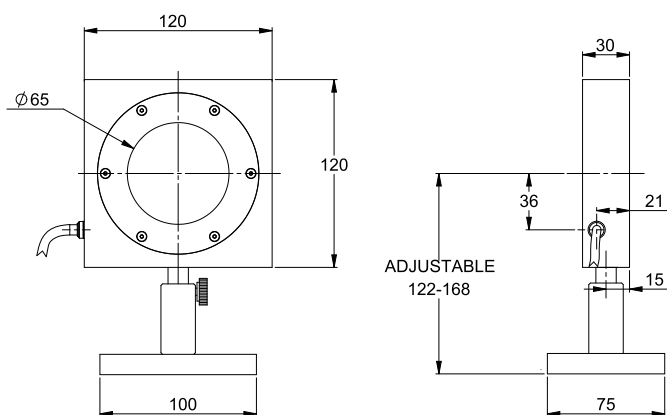

L40(150)A-IPL

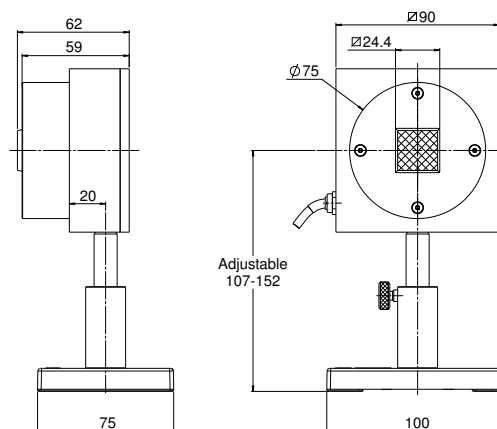

L50(300)A-LP2-65

