

1.1.2.5 Medium Power Large Aperture Thermal Sensors - Apertures 50mm

300mW to 500W and up to 10kJ

Features

- Thin profile
- CW to 40W, intermittent to 500W
- Pulse energies up to 10,000 Joules
- For continuous, long pulse and Excimer lasers
- Measure high power lasers by 0.5-4s exposures

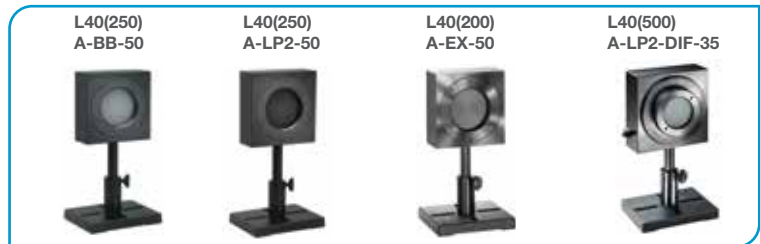

Model	L40(250)A-BB-50	L40(250)A-LP2-50	L40(200)A-EX-50	L40(500)A-LP2-DIF-35
Use	General purpose	CW and Long Pulse Lasers	Excimer lasers	Concentrated Beams
Absorber Type	Broadband	LP2	EX	LP2 + Diffuser
Spectral Range μm	0.19 - 11	0.25 - 2.2, 2.94	0.15 - 0.7, 10.6	0.44 - 2.2 ^(c)
Absorption	~88%	>94% from 0.25 to 1.1 μm	~95%	~14% backscatter from diffuser
Aperture mm	\varnothing 50mm	\varnothing 50mm	\varnothing 50 mm	\varnothing 35mm
Power Mode				
Power Range	300mW - 250W ^(b)	300mW - 250W ^(b)	300mW - 200W	300mW - 500W ^(b)
Maximum Intermittent Power	250W for 1.5min, 150W for 3min, 80W for 6min, 35W continuous ^(b)	250W for 1.5min, 150W for 3min, 80W for 6min, 40W continuous ^(b)	200W for 1.5min, 150W for 3min, 80W for 6min, 35W continuous	500W for 45s, 250W for 1.5min, 150W for 3min, 80W for 6min, 40 continuous ^(b)
Power Scales	250W / 30W	250W / 30W	200W / 20W	500W / 50W
Power Noise Level	15mW	15mW	15mW	20mW
Maximum Average Power Density kW/cm ²	10 at 250W 20 at 35W	20 at 250W 50 at 40W	1.5	>150 at 500W
Response Time with Meter (0-95%) typ. s	2.5	2.5	2.5	2.5
Calibration Uncertainty $\pm\%$	1.9	1.9	1.9	1.9
Power Accuracy $\pm\%$	3 ^(f)	3 ^(a)	3	3
Linearity with Power $\pm\%$	1	1	1	1
Beam Size Dependence	<1% for beams up to 35mm diameter			
Max Beam Diameter for Gaussian beam	\varnothing 35mm	\varnothing 35mm for up to 30deg incidence	\varnothing 35mm	\varnothing 25mm for normal incidence \varnothing 15mm for 20deg incidence ^(d) \varnothing 10mm for 30deg incidence ^(d)
Energy Mode				
Energy Range	100mJ - 4000J	100mJ - 10,000J	100mJ - 200J	100mJ - 2000J
Energy Scales	4kJ / 400J / 40J / 4J	10kJ / 1kJ / 100J / 10J	200J / 30J / 3J	2kJ / 200J / 20J / 2J
Energy Accuracy	\pm 5%	\pm 5% 700 - 1100nm ^(a, b)	\pm 5%	\pm 5% 900 - 1100nm ^(b)
Maximum Exposure Before Cooling Down is Necessary	NA	See page 110	NA	See page 110
Minimum Energy mJ	100	100	100	100
Maximum Energy Density J/cm ²				
<100ns	0.3	0.1	0.5	3
1 μ s	0.4	0.9	0.6	3
0.5ms	5	50	6	10
2ms	10	130	12	20
10ms	30	400	25	30
>300ms	See below ^(b, e)	See below ^(b, e)	NA	See below ^(b, e)
Cooling	Convection	Convection	Convection	Convection
Fiber Adapters Available (see page 126)	ST, FC, SMA, SC	ST, FC, SMA, SC	NA	NA
Weight kg	0.6	0.8	0.6	0.6
Compliance	CE, UKCA, China RoHS	CE, UKCA, China RoHS	CE, UKCA, China RoHS	CE, UKCA, China RoHS
Version	V1			
Part number: Standard Sensor	7Z07110 (1.5m cable)	7Z02794	7Z02795	7Z02797
Sensor with different cable length	7Z07110D (12m cable)			
Notes: (a) Above 1.1 μm there is an additional calibration uncertainty of up to 2% except at the additional calibration point of 2.94 μm where the additional uncertainty is 1%.				
Notes: (b) Long pulses (0.5 - 4s) can be used to measure power of high power lasers by measuring the energy of a short exposure. The StarBright, Juno, Juno+, Juno-RS and Centauri meters have a Pulsed Power mode where the user may specify the pulse width and get a reading directly in units of power for this short exposure energy measurement. See also page 110				
Notes: (c) Calibrated for 900 - 1100nm				
Notes: (d) At large angles of incidence, the position the beam hits the absorber should be offset into the direction of incidence by 5-10mm for correct reading and at 20deg incidence the reading will be 5% lower and at 30deg incidence 10% lower				
Notes: (e) Recommended exposure times and 1/e ² Gaussian beam diameters for very long pulses. Total energy for a series of measurements should not exceed 20kJ (*8kJ). Cooling down time before another 20kJ (*8kJ) series, 10min. Recommended time between shots 12s.				
Notes: (f) \pm 4%. For wavelengths <240nm	Lasers Power W	Recommended Exposure s	Number of shots before cooling down	Min 1/e ² beam dia. mm
		Non- Diffuser		L40(250)A-BB-50
		Diffuser		L40(250)A-LP2-50
				L40(500)A-LP2-DIF-35
	100	4	20	14
	500	2	20	14
	1000	1	20	14
	2000	1	10	21
	4000	1	5	32
	5000	1	4	NA
	10000	0.3	4	NA
				9
				9
				9
				12
				16
				18
				22
				1
				1
				1.5
				3.5
				NA
				NA

* For drawings please see page 69

L40(500)A-LP2-DIF-35

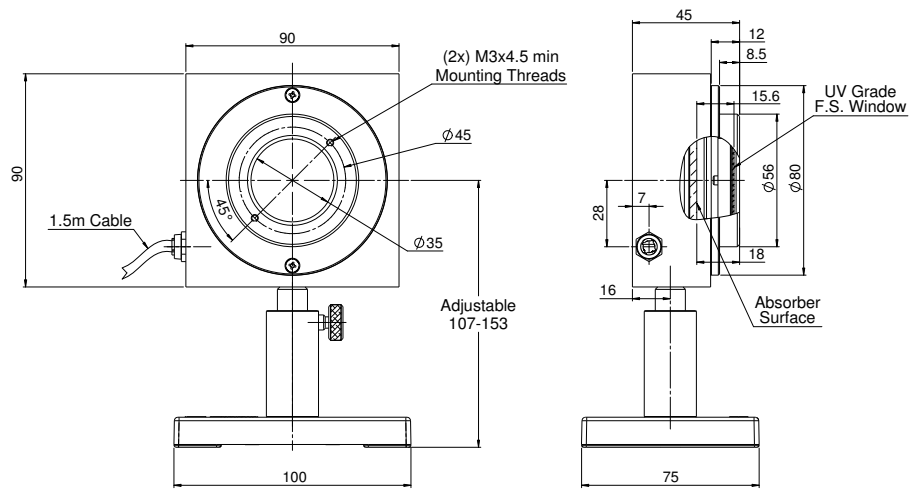

L40(250)A-BB-50 / L40(250)A-LP2-50 / L40(200)A-EX-50

