

F150A

CW & Pulsed Measurements 60mW – 150W 20mJ - 100J

Recommended Use: General use to 150W

Special Features: Fan cooled

Absorber:	Broadband, 0.19-20 μ m
Aperture:	ϕ 17.5mm
Digital Power Scales:	150W / 30W
Maximum Average Power Density:	15KW/cm ²
Power Noise Level:	3mW
Power Accuracy:	\pm 3%
Maximum Energy Density J/cm ² :	
<100ns	0.3
0.5ms	5
2ms	10
10ms	30
Response Time with Display (0-95%):	1.2s
Linearity with Power:	\pm 1%
Energy Scales:	100J / 30J / 3J
Energy Threshold:	20mJ
Cooling:	Fan

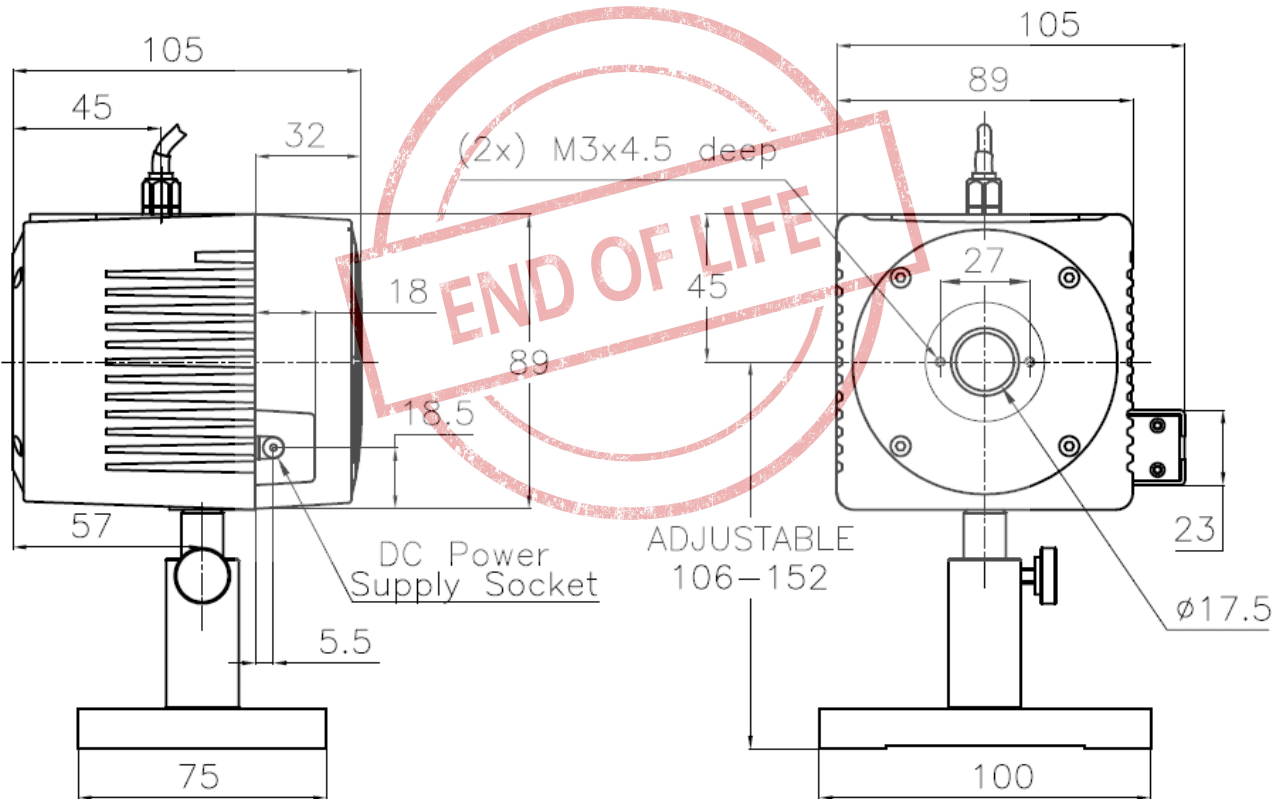

Ordering information

Item	Description	Ophir P/N
F150A-SH-V2	Fan cooled 150W power/energy meter	7Z02682 (RoHS)

Rev1/spc/22.03.09/eg

Visit our website: WWW.OPHIROPT.COM