



FOR IMMEDIATE RELEASE

For more information contact:

Gary Wagner, President, Ophir-Spiricon, gary.wagner@us.ophiropt.com

Shari Worthington, PR Counsel, Telesian Technology, sharilee@telesian.com

## New StarLab Laser Power/Energy Software Adds Support for BeamTrack, Industry's Only Power/Position/Size Sensors

September 26, 2011 – Logan, Utah – Ophir Photonics Group, the global leader in precision laser measurement equipment, today announced **StarLab 2.20**, laser measurement software that converts a PC into a multi-channel laser power/energy station. The newest version of the software includes support for the unique **BeamTrack** sensors; they combine multiple measurement functions in a single device: power, energy, beam position, and beam size. The sensors also provide information on centering and beam wander, all in a single, compact device. StarLab provides an easy-to-use, PC-based application that graphically displays, processes, and logs all these measurements.

With **StarLab 2.20**, laser sensors can be displayed separately or multiple data sets can be displayed in one graph. Graphic options include line

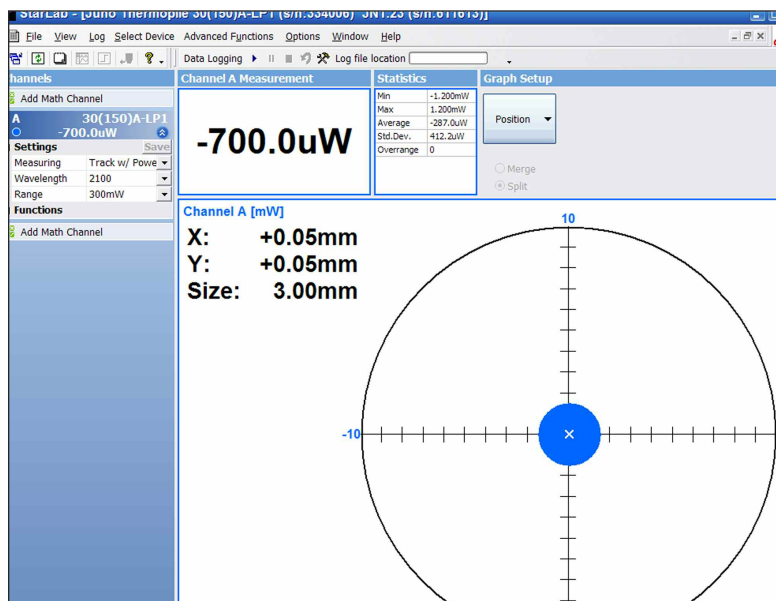

Ophir-Spiricon, LLC  
3050 North 300 West  
Logan, UT 84341  
Tel: 435-753-3729  
Fax: 435-755-5454

[www.ophiropt.com/photronics](http://www.ophiropt.com/photronics)

plot, histogram, bar chart, and simulated analog needle. Data can be displayed graphically or saved in text format. The COM object allows developers to integrate laser beam measurements into sophisticated programming environments, such as Microsoft's® Visual Basic, LabVIEW®, and MatLab®. LabVIEW support, for example, integrates real-time control and advanced analysis and signal processing functions with Ophir's Juno. The Juno is a compact USB module that connects any of Ophir's 100+ smart laser sensors – thermal, pyroelectric, or photodiode -- to a PC USB port.

With its support for **BeamTrack**, **StarLab 2.20** can now measure beam position and beam size, in addition to power and energy. Windows 7, 64 bit compatibility makes working with large data sets easier, computations faster, and multitasking more efficient.

**StarLab 2.20** works with Ophir's smart displays and PC interfaces, allowing users to measure, analyze, and record laser power and energy parameters from a wide variety of smart power/energy sensors. Data can be collected from thermal, pyroelectric, and photodiode heads using any of the company's laser power/energy meters, PC interfaces, or combinations of the two.

- **Juno:** USB laser sensor to PC interface; multiple devices connect up to eight (8) heads to one PC
- **USBI:** USB laser sensor to PC interface
- **Vega:** compact, stand-alone meter with bright, color display
- **Nova II:** high definition, stand-alone meter with LCD display
- **Pulsar:** high speed, multi-channel USB meter supports data logging to PC, up to 25,000 Hz
- **Quasar:** wireless Bluetooth meter with range >10 meters to PC

### **Pricing and Availability**

**StarLab 2.20** is available now. It is included free of charge with all **Juno**, **USBI**, **Vega**, **Nova II**, **Pulsar**, and **Quasar** power/energy meters. It works on Microsoft® Windows® 2000, XP, Vista (32-bit), and Windows 7 (32-bit and 64-bit) platforms.

The StarLab data sheet and firmware download can be found at:  
<http://www.ophiropt.com/en/laser-measurement-instruments/laser-power-energy-meters/software/starlab>

The BeamTrack data sheet can be downloaded at  
<http://www.ophiropt.com/laser-measurement-instruments/laser-power-energy-meters/products/power-sensors/beamtrack-sensors>

## **About Ophir Photonics Group**

With over 30 years of experience, the Ophir Photonics Group provides a complete line of instrumentation including power and energy meters, beam profilers, spectrum analyzers, and goniometric radiometers. Dedicated to continuous innovation in laser measurement, the company holds a number of patents, including Ophir-Spiricon's **Ultracal™**, the baseline correction algorithm that helped establish the ISO 11146-3 standard for beam measurement accuracy. The recently acquired Photon family of products includes **NanoScan** scanning-slit technology, which is capable of measuring beam size and position to sub-micron resolution. The company's modular, customizable solutions serve manufacturing, medical, military, and research industries throughout the world. For more information, visit <http://www.ophiropt.com/photonics>

###

### **For more information, contact:**

Gary Wagner, President  
Ophir-Spiricon, LLC  
3050 North 300 West  
North Logan, UT 84341  
Tel: 435-753-3729  
E-mail: [gary.wagner@us.ophiropt.com](mailto:gary.wagner@us.ophiropt.com)  
Web: [www.ophiropt.com/photonics](http://www.ophiropt.com/photonics)

### **PR Office:**

Shari Worthington  
Telesian Technology  
49 Midgley Lane  
Worcester, MA 01604  
Tel: 508-755-5242  
E-mail: [sharilee@telesian.com](mailto:sharilee@telesian.com)

© 2011, Ophir Photonics Group. Ultracal and BeamGage are trademarks of Ophir-Spiricon, LLC. All other trademarks are the registered property of their respective owners.